

• General Description

The ZM085N03S combines advanced trench MOSFET technology with a low resistance package to provide extremely low $R_{DS(ON)}$.

• Features

- Advance high cell density Trench technology
- Low $R_{DS(ON)}$ to minimize conductive loss
- Low Gate Charge for fast switching
- Low Thermal resistance

• Application

- POL application
- BLDC Motor driver

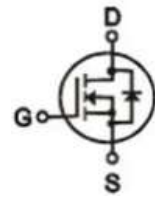
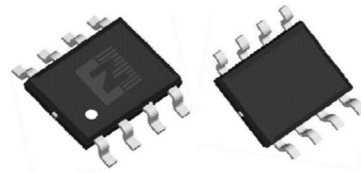
• Product Summary

 $V_{DS}=30V$
 $R_{DS(ON)}=8m\Omega$
 $I_D=15A$

SOP-8

• Ordering Information:

Part NO.	ZM085N03S
Marking	ZM085N03
Packing Information	REEL TAPE
Basic ordering unit (pcs)	4000

• Absolute Maximum Ratings ($T_C=25^\circ C$)

Parameter	Symbol	Rating	Unit
Drain-Source Voltage	V_{DS}	30	V
Gate-Source Voltage	V_{GS}	± 20	V
Continuous Drain Current ^②	$I_{D@TC=25^\circ C}$	15	A
	$I_{D@TC=75^\circ C}$	11.4	A
	$I_{D@TC=100^\circ C}$	9.5	A
Pulsed Drain Current ^①	I_{DM}	35	A
Total Power Dissipation ^②	$P_D@TC=25^\circ C$	3.1	W
Total Power Dissipation	$P_D@TA=25^\circ C$	0.69	W
Operating Junction Temperature	T_J	-55 to 150	$^\circ C$
Storage Temperature	T_{STG}	-55 to 150	$^\circ C$
Single Pulse Avalanche Energy@L=0.1mH	E_{AS}	39.2	mJ
Avalanche Current@L=0.1mH	I_{AS}	28	A

**•Thermal resistance**

Parameter	Symbol	Min.	Typ.	Max.	Unit
Thermal resistance, junction - case ^②	R _{thJC}	-	-	40	° C/W
Thermal resistance, junction - ambient	R _{thJA}	-	-	180	° C/W
Soldering temperature, wavesoldering for 10s	T _{sold}	-	-	265	° C

•Electronic Characteristics

Parameter	Symbol	Condition	Min.	Typ	Max.	Unit
Drain-Source Breakdown Voltage	BV _{DSS}	V _{GS} =0V, I _D =250uA	30			V
Gate Threshold Voltage	V _{GS(TH)}	V _{GS} =V _{DS} , I _D =250uA	1.2		2.5	V
Drain-Source Leakage Current	I _{DSS}	V _{DS} =30V, V _{GS} =0V			1.0	uA
Gate- Source Leakage Current	I _{GSS}	V _{GS} =±20V, V _{DS} =0V			±100	nA
Static Drain-source On Resistance	R _{DS(ON)}	V _{GS} =10V, I _D =12A		8	10	mΩ
		V _{GS} =4.5V, I _D =6A		11	13	mΩ
Forward Transconductance	g _{FS}	V _{DS} =25V, I _D =10A		9		s
Source-drain voltage	V _{SD}	I _S =12A			1.28	V

•Electronic Characteristics

Parameter	Symbol	Condition	Min.	Typ	Max.	Unit
Input capacitance	C _{iss}	V _{DS} =25V f = 1MHz	-	1200	-	pF
Output capacitance	C _{oss}		-	235	-	
Reverse transfer capacitance	C _{rss}		-	120	-	

•Gate Charge characteristics(Ta= 25°C)

Parameter	Symbol	Condition	Min.	Typ	Max.	Unit
Total gate charge	Q _g	V _{DD} =15V	-	12	-	nC
Gate - Source charge	Q _{gs}	I _D = 12A	-	4	-	
Gate - Drain charge	Q _{gd}	V _{GS} = 10V	-	6	-	

Note: ① Pulse Test : Pulse width ≤ 300μs, Duty cycle ≤ 2% ;

② Device mounted on FR-4 substrate PC board, 2oz copper, with thermal bias to bottom layer 1inch square copper plate;

Fig.1 Power Dissipation

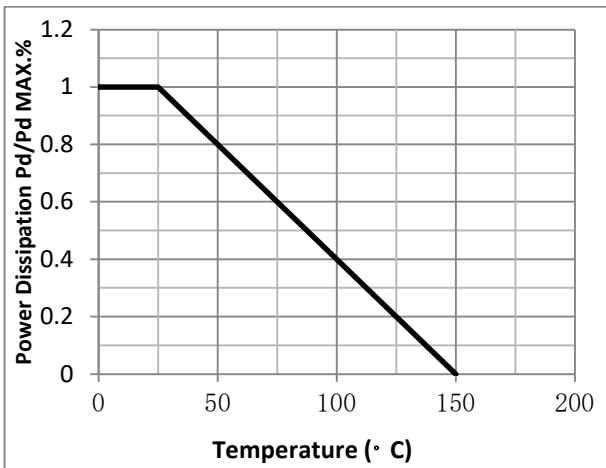

Fig.2 Typical output Characteristics

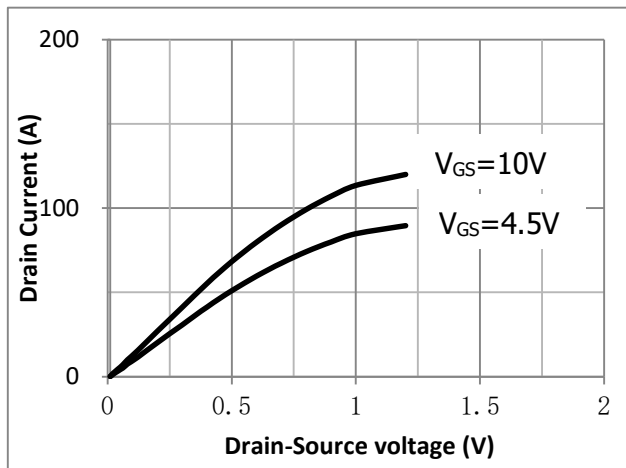

Fig.3 Threshold Voltage V.S Junction Temperature

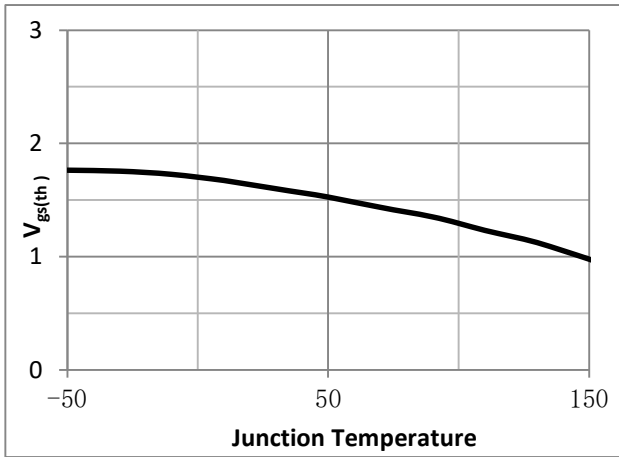

Fig.4 Resistance V.S Drain Current

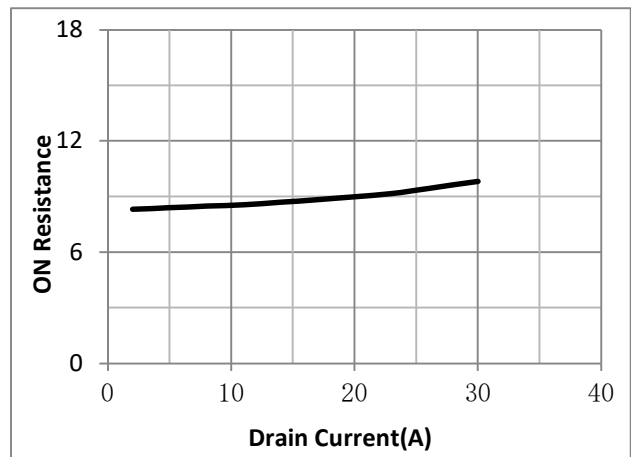

Fig.5 On-Resistance VS Gate Source Voltage

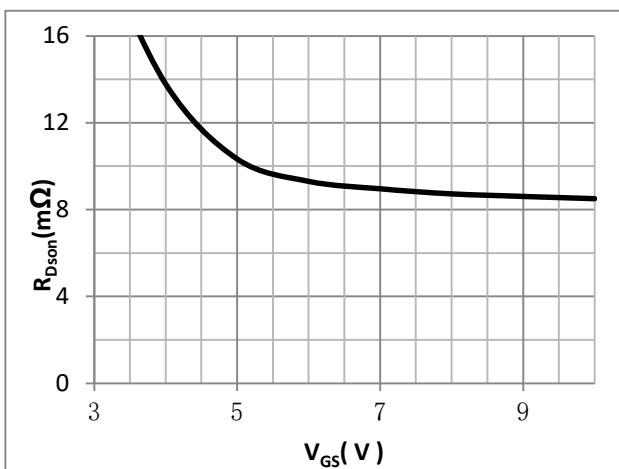

Fig.6 On-Resistance V.S Junction Temperature

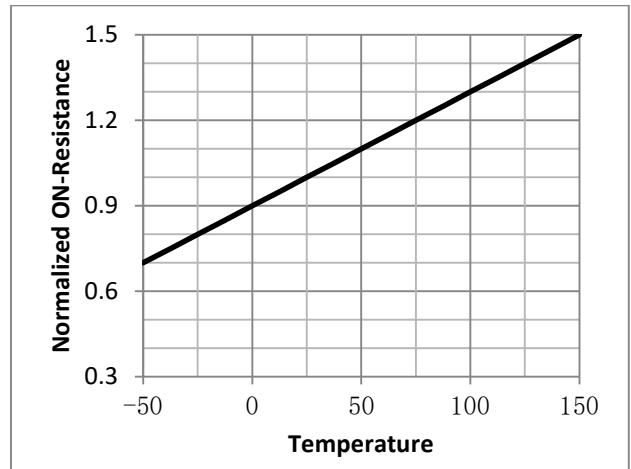

Fig.7 Gate Charge Measurement Circuit

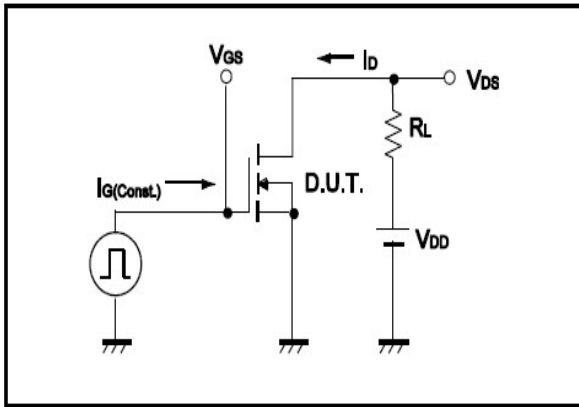

Fig.8 Gate Charge Waveform

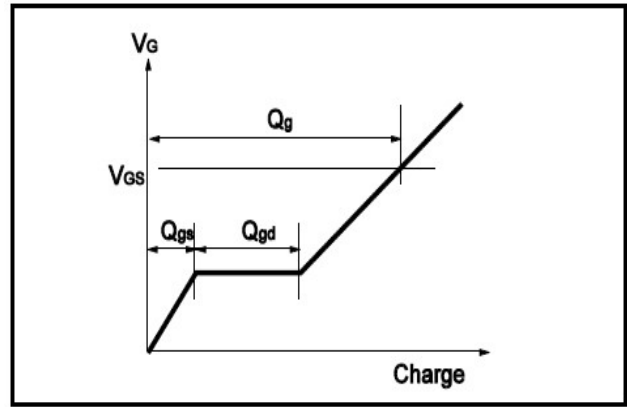

Fig.9 Switching Time Measurement Circuit

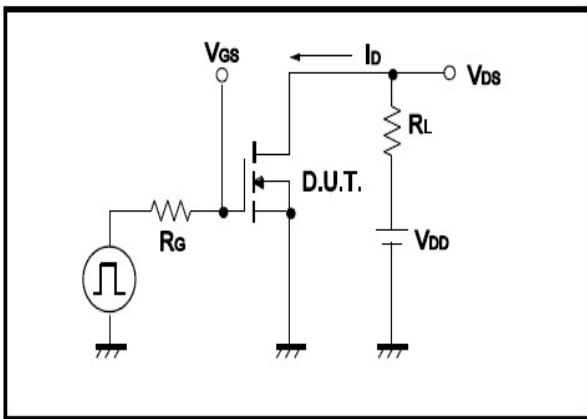

Fig.10 Switching Time Waveform

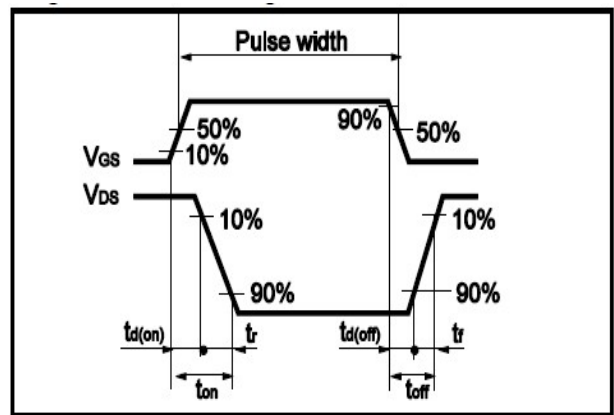

Fig.11 Avalanche Measurement Circuit

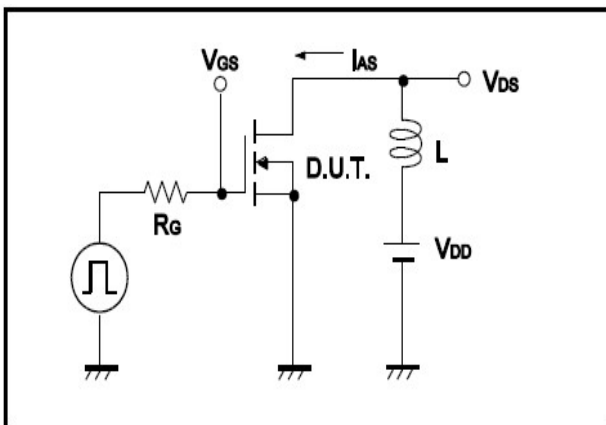
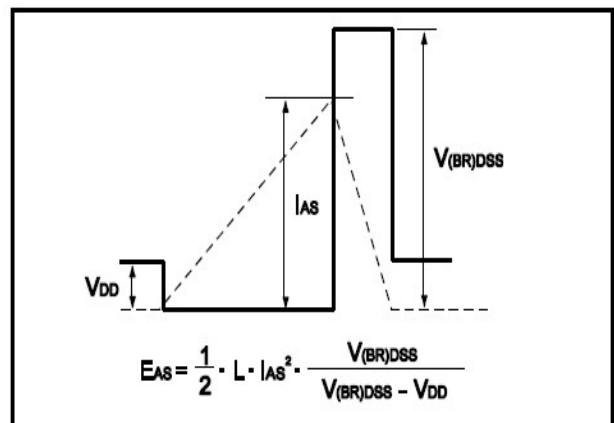

Fig.12 Avalanche Waveform



•Dimensions(SOP8)

Unit: mm

SYMBOL	min	TYP	max	SYMBOL	min		max
A	4.80		5.00	C	1.30		1.50
A1	0.37		0.47	C1	0.55		0.75
A2		1.27		C2	0.55		0.65
A3		0.41		C3	0.05		0.20
B	5.80		6.20	C4	0.19	0.20	0.23
B1	3.80		4.00	D		1.05	
B2		5.00		D1	0.40		0.62

